

1、 DIMENSION DIAGRAM (Unit: mm)

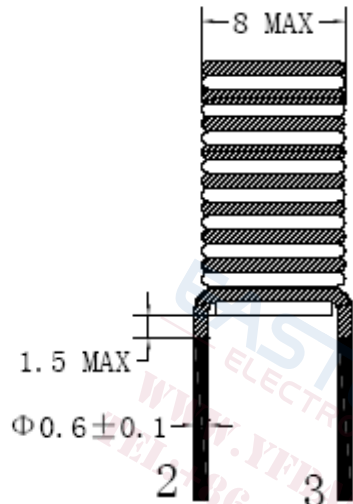
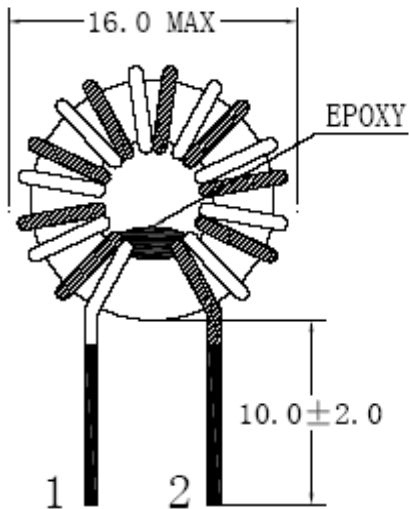

2、 BILLOF MATERIALS

CORE:T12*6*4C R15K

SOLDER:Sn99.3-0.7-S002

WIRE:0.60mm (2UEW)

WIRE:0.60mm(TIW-2)

EPOXY:G500/H210

3、 ELECTRICAL STRUCTURE

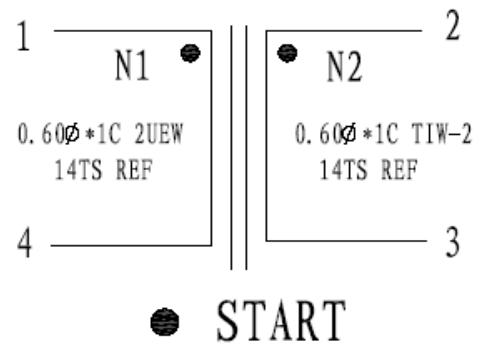

4、 ELECTRICAL CHARACTERISTICS:

- TURNS : 1-4=2-3=14.0TS(REF)
- TEST FREQUENCY : 1KHz/0.3V(TH2776B)
- INDUCTANCE : 1-4=2-3=1.2mH(Min)
- RDC : 1-4=2-3=0.050Ω(Max)
- HI-POT TEST : 500V/AC 5mA/2Sec