

1、 DIMENSION DIAGRAM (Unit:mm)

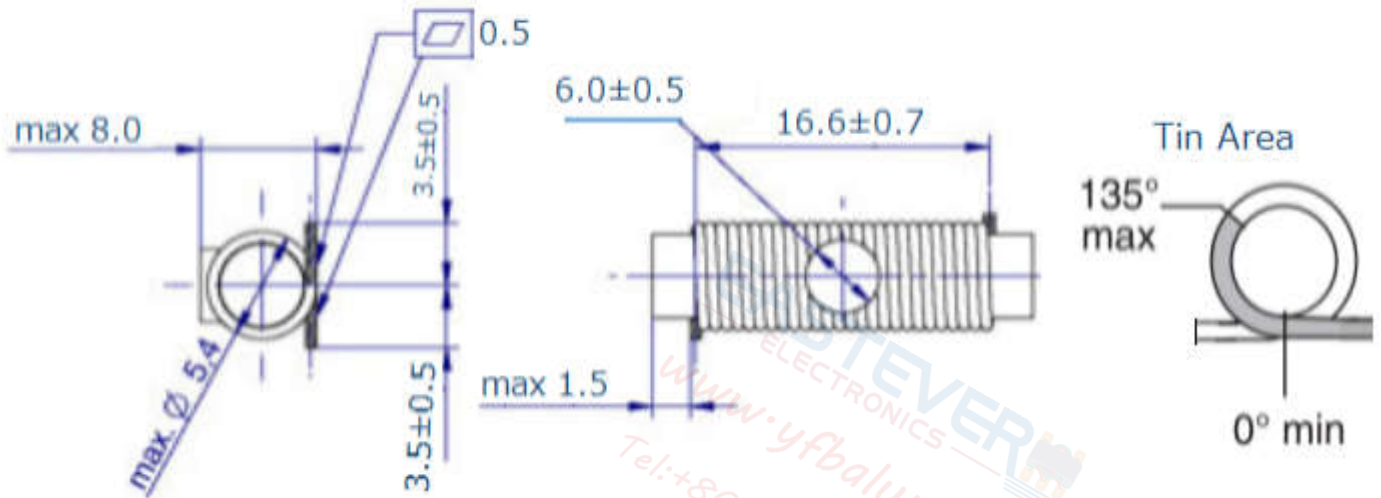

2、 BILL OF MATERIALS :

R Core: R5.0X18.0+2.0 Ferrite material
 Wire: QA-0.70
 Case: Φ6.0X0.5
 Epoxy: TH308



3、 ELECTRICAL STRUCTURE:

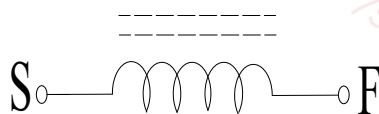

4、 ELECTRICAL CHARACTERISTICS:

Turns : 22.0TS(Fixed)
 Test Frequency : 1.0KHz/0.3V(TH2776B)
 Inductance : 8.2uH±20%
 DC R : 30. 0mΩ Max
 Rated Current : 2.0A Max
 Operating temperature range: -40℃ to +85℃
 Storage temperature range: -45℃ to +105℃